

SWIVEL HYDRANT

WATER MANAGEMENT

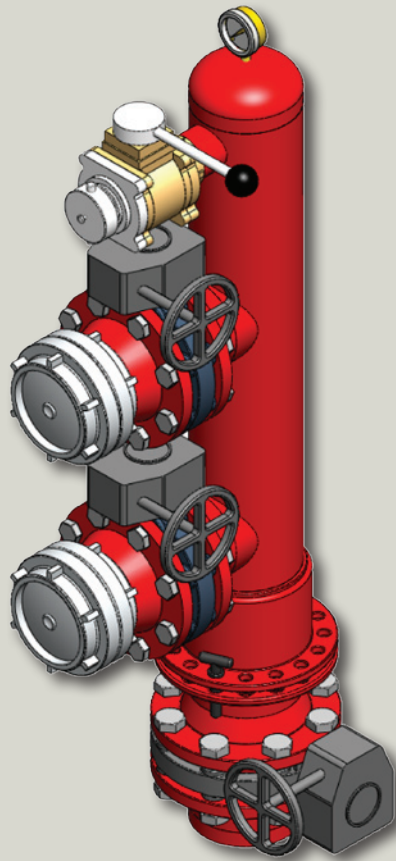

DESIGN MOTIVATION

Fire field logistics are ranked nearly as high as equipment on hand and personnel available when facing industrial responses. Large fires require large volumes of water, which sometimes require multiple large diameter water supply hoses. The most convenient, reliable, and safest means of distributing large volumes of water over an entire facility is by constructing underground water delivery systems with above ground hydrant manifolds. These hydrant manifolds are then used in conjunction with large diameter water supply hose to supply the necessary water to pumps, fire nozzles, and foam proportioning equipment.

Williams Fire and Hazard Control is now developing a line of new hydrant manifolds with an incorporated 360 degree rotating swivel built into the main riser of the unit. This swivel will allow the first responders to reposition the hydrant in the most advantageous direction depending on the location of the hazard and lock it into place using onboard swivel lock.

DESIGN BENEFITS

- Reduction in total hose required due to eliminating initial bend radius
- Reduction in road blockage due to initial hose bends running across roadways
- Conservation of pressure due to shorter hoses needed
- Suitable for highly congested areas (vertical design)
- Suitable for a wide range of flows up to 10,000gpm
 - Built with the industrial fire fighter in mind
 - Robust design using swivels capable of supporting several tons of side load
 - Fully serviceable with integrated swivel grease zerks
 - By more efficiently supplying water, swivel hydrants could reduce the number of necessary hydrant locations by as much as 50% (depending on hydrant layout and size)

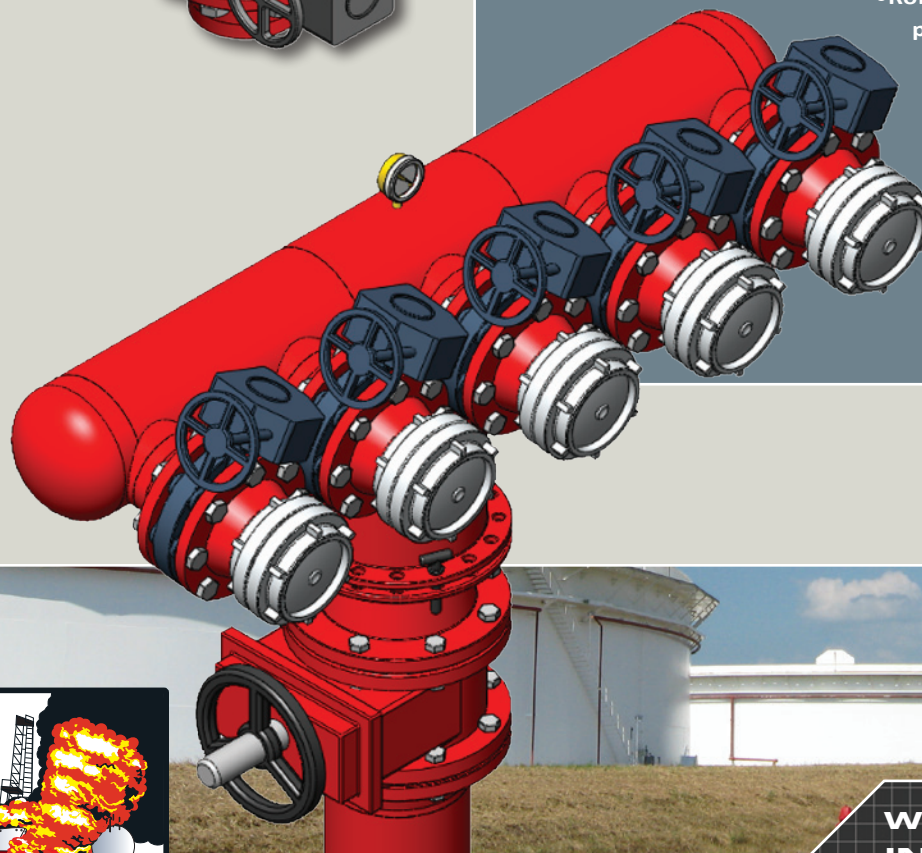

WWW.WILLIAMSFIRE.COM
INFO@WILLIAMSFIRE.COM

PRODUCTS 800-231-4613
EMERGENCY 409-727-2347
281-999-0276

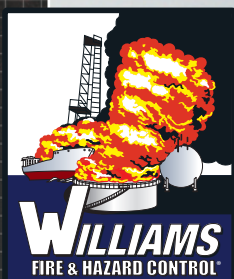

SWIVEL HYDRANT

SPECS

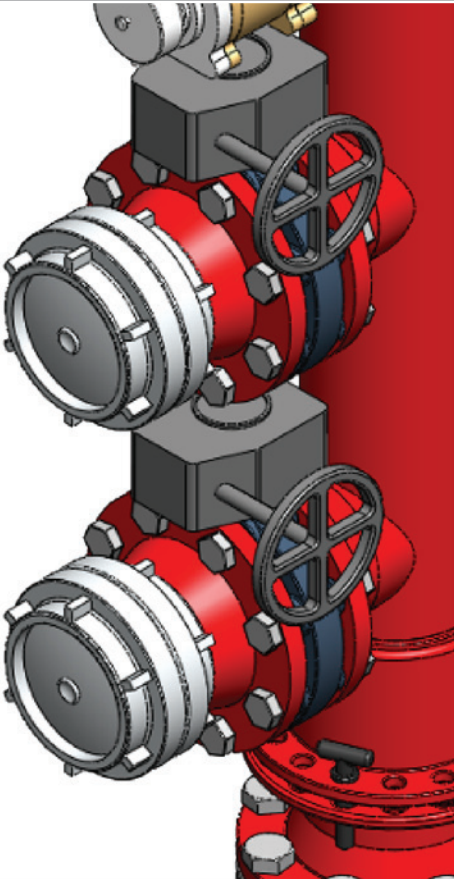

SIZING GUIDE

- The below figures are based on a 24" underground header with 8' of vertical piping extending to base of the hydrant. Loss numbers are from underground header inlet point to hydrant discharge (hose connection). Numbers will vary based on outlet valve and connection type/size selected.
- Hydrant size recommendations made on case-by-case basis.
- These recommendations are based on hazards present and water flow required for suitable protection.

6" RISER/HYDRANT (APPROXIMATE CV = 950)

- 1,000gpm – 1psi loss
- 2,000gpm – 4.5psi loss
- 3,000gpm – 10psi loss

8" RISER/HYDRANT (APPROXIMATE CV = 1730)

- 3,000gpm – 3psi loss
- 4,000gpm – 5.3psi loss
- 6,000gpm – 12psi loss

10" RISER/HYDRANT (APPROXIMATE CV = 2670)

- 6,000gpm – 5psi loss
- 8,000gpm – 9psi loss
- 10,000gpm – 14psi loss

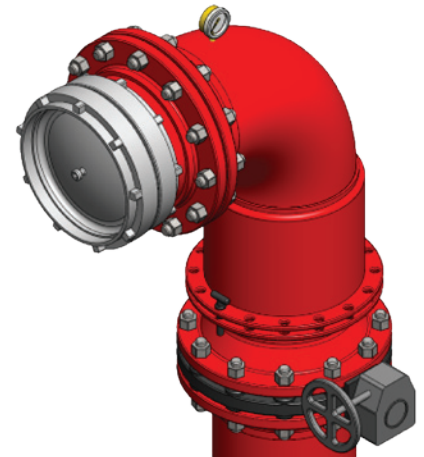
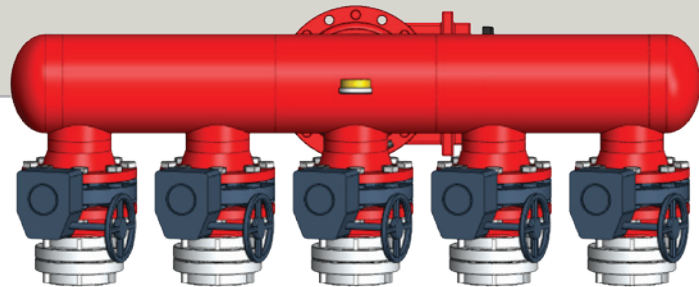

AVAILABLE DESIGN CHOICES

- Various material designs (carbon steel, 304L stainless steel, 316L stainless steel)
- Various inlet and riser sizes (4", 6", 8", 10" available now, 12" in development)
- Various header designs (vertical stack, traditional Tee, or single 90° outlet)
- Various discharge options (NST, BSP, Storz, etc.)
- Various discharge sizes (1-1/2" – 12")
- Integrated swivel lock standard to prevent movement after positioning
- Available with discharge valves, check valves, caps, or pressure gauges
- Available with integrated monitor mount
- Available with integrated automatic hydrant drain valve (below swivel)
- Available with hydrant inlet valve (between hydrant swivel and header connection)

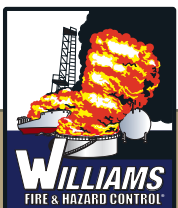

WWW.WILLIAMSFIRE.COM
INFO@WILLIAMSFIRE.COM

PRODUCTS 800-231-4613
EMERGENCY 409-727-2347
281-999-0276